



460 Southport Commerce Blvd.
 Spartanburg SC 29306
 Phone: 864-574-6004
 Fax: 864-574-6005
 www.ojedausa.com
 sales@ojedausa.com

Project: _____
 Model #: _____
 Item #: _____ Qty: _____
 Approval: _____

GLASS DOOR MERCHANDISERS

RMH-27



R-290 REFRIGERANT

Equipped with R-290 refrigerant, an eco-friendly alternative that meets the EPA's environmental impact regulations.

CARE FREE CONDENSER

The finless spiral condenser design prevents dust/dirt buildup allowing maximum long term efficiency.

ELECTRONIC CONTROL

The intelligent temperature control is programmed to ensure the correct operation of the equipment and maintain products at an optimum temperature.

LED LIGHTING

LED lighting lasts longer than fluorescent lighting, it reducing energy consumption, which generates minimal heat. All of this makes LED lighting great for the environment.

HOT GAS EVAPORATION

Hot gas heated drain pan for condensate evaporation that eliminates the need of floor drains or electric heaters.

OPERATION TEMPERATURE

36°F to 40°F

CUSTOM GRAPHICS

Standard color: black.

Dimensions			Crated Dimensions			Shelves	HP	Voltage	NEMA config	Amps	Crated Weight		
	W	D	H		W	D	H	5	1/4+	120	5-15P	5	341 lbs
(in)	30.1	30.9	79.1	(in)	31.7	33.1	83.4	Net Capacity (cf): 23			Energy Consumption: 2.95 kw-hr/24 hrs		
(mm)	763	785	2010	(mm)	803	840	2117						

*Inches rounded up one decimal place *Specifics may change without notification



CABINET CONSTRUCTION

- High-density, CFC-Free, polyurethane insulation
- Large low-E double pane tempered thermal glass side panels
- Exterior: galvanized metal cabinet with powder coated painted surface
- Interior: easy to clean pre-painted steel
- Self closing door
- Recessed pocket handle

SHELVING

- Adjustable shelves

OPERATING CONDITIONS

- The unit is best suited for an environment where temperatures remain below 85°F and humidity does not exceed 55%.
- Areas with direct sunlight should also be avoided.

REFRIGERATION

- Maintenance free condenser
- Automatic defrost cycle
- Hot gas heated pan for condensate evaporation
- R-290 refrigerant

OPTIONS

- 6" stainless steel legs
- Heavy duty casters 3" and 5"
- Custom graphics

WARRANTY

- 3 year parts and labor warranty
- 5 year compressor

LIGHTING

- Vertical LED lighting

6 INCH ADJUSTABLE LEGS

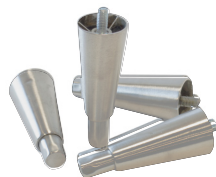

HEAVY DUTY CASTERS

(3" and 5")

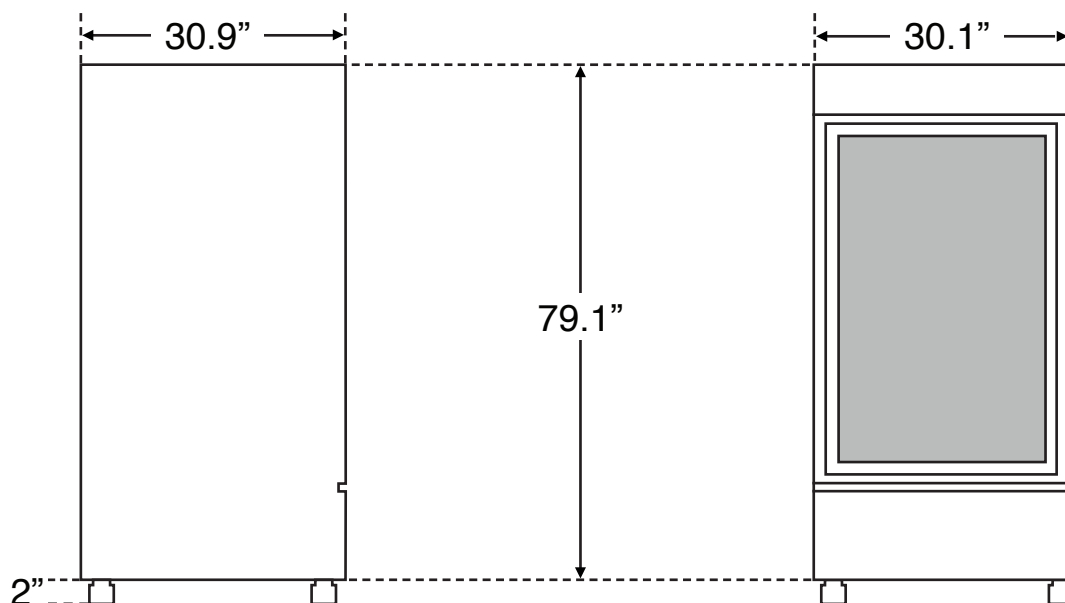

*Specifics may change without notification

